

Installation instructions

Polyethylene shafts

Eco-Line series (rainwater)

Clearo-Line series (wastewater)

Ozeanis series (rainwater)

1000 L / 1500 L / 2000 L

Version 02-2026

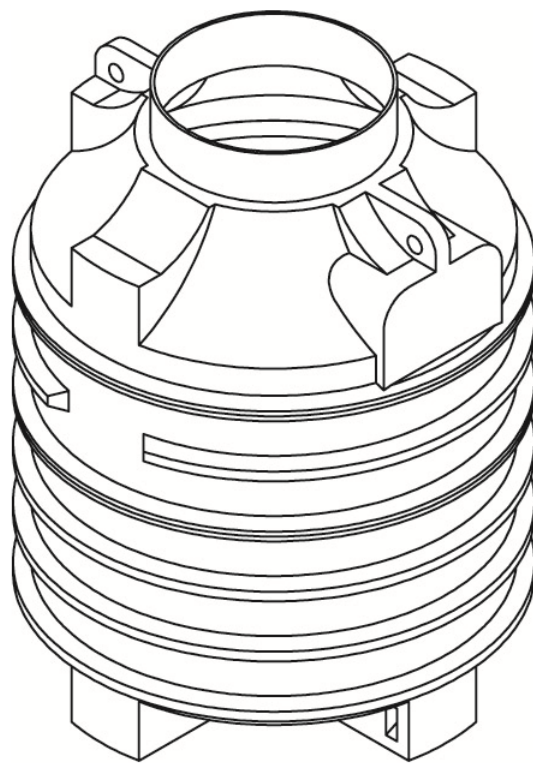

tilus
EME

Table of contents

1.	Safety and labelling obligation.....	3
2.	Overview volumes, dimensions, empty weights.....	3
3.	General.....	4
3.1	About these instructions.....	4
3.2	General information about earth shafts.....	4
3.3	Legal position / regulatory requirements.....	4
3.4	General building requirements.....	4
3.5	Liability.....	5
4	Site selection and site requirements.....	5
4.1	Soil conditions.....	5
4.2	Location to buildings.....	5
4.3	Excavation pit.....	6
4.4	Efficiency of the covers.....	6
4.5	Slope.....	8
4.6	Traffic areas.....	8
4.7	Frost resistance.....	8
4.8	Special installation situation.....	8
5	Backfill material.....	8
5.1	For the pit area around the shaft.....	8
6	Execution and timing of installation.....	9
6.1	Installation as a wastewater collection shaft / rainwater collection shafts.....	9
6.2	Installation of trafficable version.....	10
7	Maintenance and cleaning.....	12

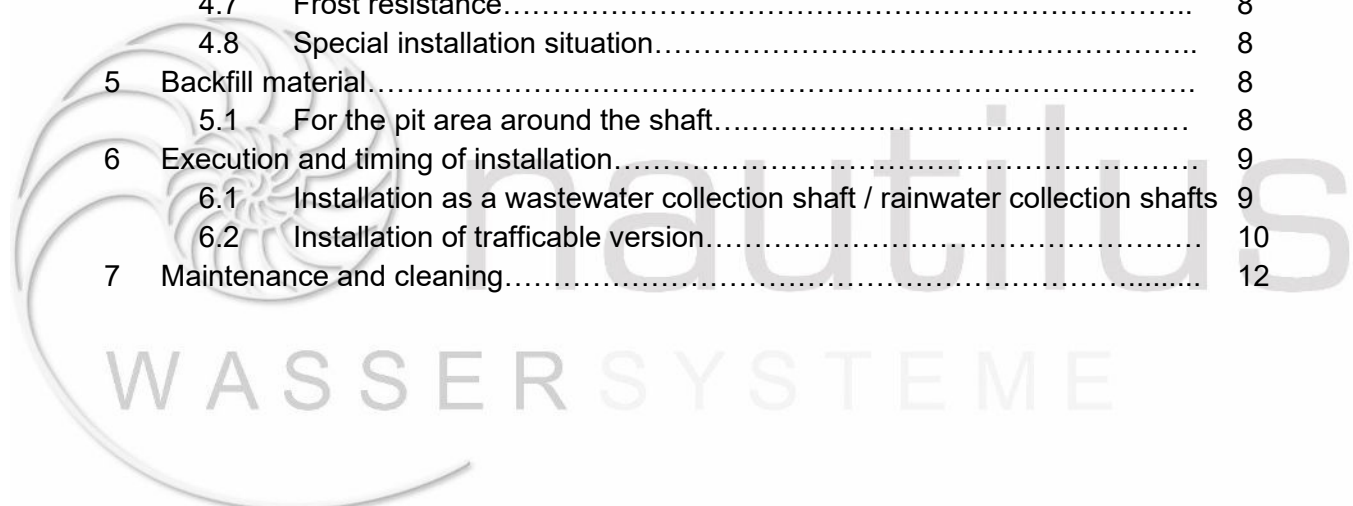

1 Safety and labelling obligation

1.1 Safety

For all work, the relevant accident prevention regulations, in accordance with DGUV V32, among others, are to be observed, using appropriate safety equipment.

A 2nd person is required for safety purposes when inspecting the tanks.

The systems must always be put out of operation during works or maintenance and secured against unauthorised use.

The lid to the tank must remain closed, except when working inside the tank, to reduce the risk of accidents.

Nautilus Wassersysteme GmbH & Co KG offers an extensive range of accessories, all of which match one another and can be converted into complete systems.

Use of other accessories may impair the system’s functionality and lead to exclusion of liability for any resulting damage.

1.2 Labelling obligation

All pipes and service water outlets are to be labelled or depicted with the words “**Not drinking water**“ (DIN 1988 Part 2, Para. 3.3.2.) in order to prevent an erroneous connection with the drinking water supply, even when many years have passed. Even correct labelling can cause confusion, e.g. with children. For this reason, all domestic water – water taps with valves must be **child-proof**.

2 Overview volumes, dimensions, empty weights

Shafts table 1: Overview volumes, dimensions, empty weight

Volumes	Dimensions L x B x H:	Empty weight
Eco-Line 1000 Litre	Diameter 1120 x 1580 mm	approx. 48 kg
Clearo-Line 1000 Litre Ozeanis 1000 Litre	Diameter 1310 x 1360 mm	approx. 48 kg
Clearo-Line 1500 Litre Ozeanis 1500 Litre	Diameter 1310 x 1730 mm	approx. 68 kg
Clearo-Line 2000 Litre Ozeanis 2000 Litre	Diameter 1310 x 2100 mm	approx. 95 kg

Weights without equipment

3 General

3.1 About these instructions

Please read these instructions carefully and in full before installing and commissioning the tanks. The points described must be observed. For any additional items purchased, you will find (depending on the product) separate installation instructions in the delivery packaging. Please keep these instructions in a safe place for future reference.

These instructions cannot cover all the specifics and details of the installation of rainwater harvesting systems.

3.2 General information about the earth shafts

The earth shafts are manufactured in rotational sintering procedure from the plastic polyethylene as a single piece (monolithic) i.e. without welding seams or similar joints. The active component is resistant to almost all chemicals, contains no harmful biological agents and food-safe.



The containers are suitable for both underground and above-ground installation and filling. For above-ground installation, please refer to the separate installation instructions.



The shaft and its installations must be checked to ensure that they are intact. Any damage caused in transit must be reported to the carrier in writing upon goods receipt.



Compliance with the information in these instructions forms part of the warranty conditions. Failure to comply will void any claim under the warranty.



If covers and/or shaft extensions are used that were not purchased, listed or defined by the manufacturer, the warranty may expire under certain circumstances because conformity may not be given or heights may be exceeded, etc.

3.3 Legal position / regulatory requirements

The construction and operation of rainwater harvesting systems does not usually require a permit, however, you are obliged to notify the authorities. Even so, speak to the local authority (building control department, water supply company) about the details and any possible funding. In the manufacture and installation of rainwater harvesting systems, relevant regulations such as DIN 1989; DIN 1986; DIN 18196; ENV 1046; DIN 4124; ATV-DVWK A127 must be observed; and it is this content that forms the basis for the water systems by the company Nautilus Wassersysteme and these instructions.

The **installation of the wastewater shafts** is to be carried out solely by those **companies** with professional experience, suitable equipment and facilities, as well as sufficiently trained personnel. **This installation instruction** includes the installation of the septic tank.

3.4 General building requirements

When selecting the installation site, care must be taken to ensure that the septic tank is accessible at all times and that disposal of the wastewater is possible at all times. The distance between the installation from existing and planned water extraction plants must be large enough to prevent any adverse effects. In water conservation areas, the respective state regulations must be observed. Any downstream infiltration systems must be operational. The installation and operation of wastewater collection systems usually requires approval by the local water authority or a water permit. Please contact the responsible authority for this.

Installation instructions Earth Shafts

3.5 Liability

The manufacturer shall not be held liable for any damage caused by:

- Incorrect location selection
- Improper installation and compaction
- Groundwater, stratified water and backwater
- Misuse

We reserve the right to a tolerance of +/- 3 % for all dimension and content specifications contained in our catalogues, installation instructions and other documentation. Depending on the equipment, the usable volume of the underground tanks can be up to 10% below the nominal volume. Any errors and changes to individual products are reserved within the scope of further technical development.

4 Site selection and site requirements

4.1 Soil conditions

The subsoil must have sufficient load-bearing capacity and the surrounding soil must be capable of water absorption (a soil survey should be requested from the local building control department to determine the physical conditions of the soil). The shafts must not stand in a loamy environment in groundwater, stratified water or backwater. Ask your specialist dealer about special installation measures. In the case of soakaways, the water absorption capacity of the soil must be demonstrated (soil survey) and the highest groundwater level must be at least 1.5 metres below the lower edge of the shaft.

4.2 Location to the buildings

The tanks must not be built over, and cannot absorb loads from buildings or foundations. The distance to buildings should be at least be one single width of the tank.

Figure 1

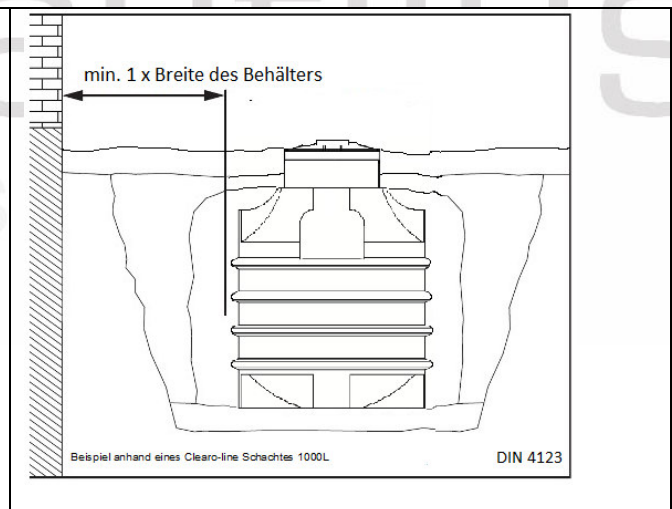

Installation instructions Earth Shafts

4.3 Excavation pit

The depth of the excavation pit is determined by the size of the shaft, frost resistance (point 3.6), existing pipes, (if provided) an external filter system and the maximum permissible earth cover of 1.5 metres above the shaft.

Table 2: Soil cover *based on the tank crown without the dome (==> see Figure 2 on page 6)

Soil cover (Hü)*			
Cover	Shaft 1000 L	Shaft 1500 L	Shaft 2000 L
Basic cover	270 mm	270 mm	270 mm
PE cover	375 mm	375 mm	375 mm
Telescopic segment	455 - 595 mm	455 - 595 mm	455 - 595 mm
Telescopic dome	720 - 970 mm	720 - 970 mm	720 - 970 mm
max. soil cover	1500 mm	1500 mm	1500 mm

4.4 Efficiency of the covers

Table 3 Efficiency of the covers

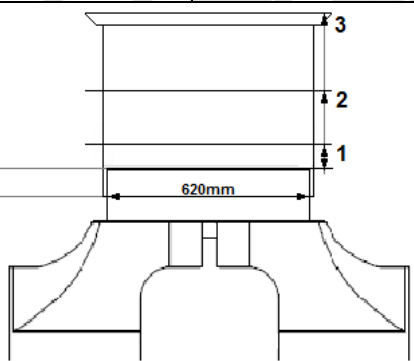
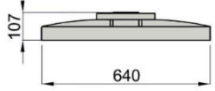
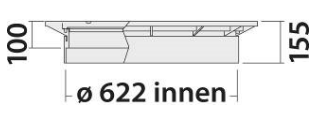
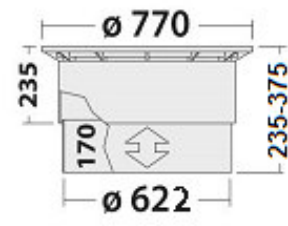
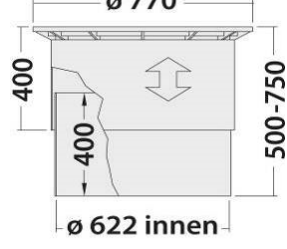
Slip lid (for rainwater only) 35.0000.0029	1 PE cover loadable up to 200kg 95.0050.0070	2 PE Telescopic segment loadable up to 1500kg 95.0050.0074	3 PE Telescopic dome loadable up to 1500kg 95.0050.0072
			
Effective height= H d		Clearoline Ozeanis Shafts	
			
	H d= 105mm	H d max. = 325mm H d min. = 185mm	H d max. = 700mm H d min. = 450mm
Description of covers			

Installation instructions Earth Shafts

<p>Not child-proof Not walkable For rainwater use only</p>	<p>Walkable Child-proof</p>	<p>Due to infinitely variable height adjustment, the effective height can be varied between 185 and 325 mm. A further reduction of the effective height is possible by shortening the segment parts.</p> <p>Walkable Child-proof</p>	<p>Due to infinitely variable height adjustment, the effective height can be varied between 450 and 700 mm. A further reduction of the effective height is possible by shortening the segment parts.</p> <p>Car-trafficable: Child-proof</p>
---	---	--	--

Figure 2: Installation sizes

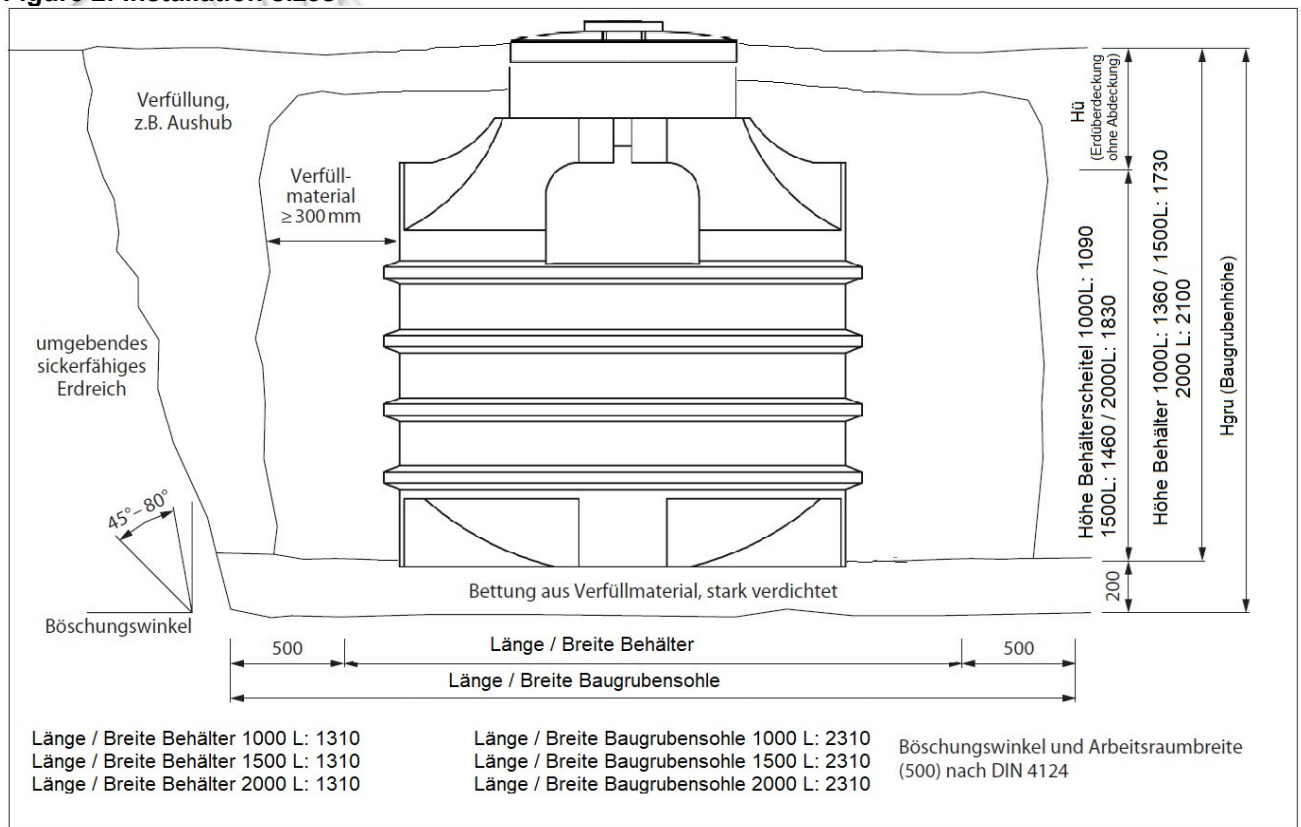

Dimensional tolerances due to production may occur in both the earth shaft and the tank covers. In the case of a possible combining of two products that lie in the upper tolerance range, it may be necessary to remove material on site. This can be achieved by carefully chamfering the tank dome or respective cover!

Installation instructions Earth Shafts

4.5 Slope

On a slope, the terrain must be checked to prevent soil slippage. When installing the tank in the immediate vicinity (< 5 m) of a slope, mound or embankment, a statically calculated supporting wall must be erected to absorb the earth pressure. The wall must exceed the tank dimensions by at least 0.5m in all directions and have a minimum distance of 1m to the tank. For more information, please contact your local authority or construction company.

Figure 3

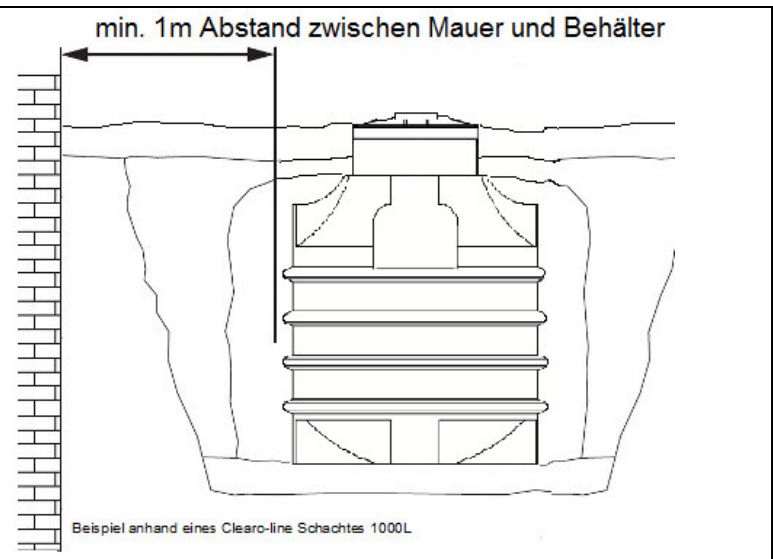

4.6 Traffic areas

Please refer to point **6.2 Installation trafficable version**

4.7 Frost resistance

In addition to frost resistance, according to DIN 1986-100, an installation depth up to the upper edge of the supply pipe of 80 cm applies to Central Europe; more detailed information is available from the local authorities. In the case of gardens, there are lower requirements for frost resistance, as the systems are not used in the event of frost.

4.8 Special installation situations

Tree populations, existing pipelines, groundwater flows etc. must be taken into account in order to rule out impairments and hazards.

5 Backfill material

5.1 For the pit area around the tank

The backfill material must be easily compacted, permeable, shear-resistant, frost-proof and free of sharp objects. These requirements are met, for example, by rounded gravel grain or gravel mixtures with widely graded grain sizes up to 32 mm made from round gravel with not broken particles. Gravel with a grain size of 2-16 (2-16mm) or comparable is required for backfilling around the shafts, below the inlet height.

Excavated soil may be used if it meets the criteria listed above.

Excavated soil or "filling sand" does not meet the above-mentioned requirements in many cases.

Topsoil, clay and other cohesive soils are unsuitable for backfilling.

The grain spectrum must be significantly more than one grain size to be able to form a solid pack.

Modifications for soakaway See point 6.3

Installation instructions Earth Shafts

The backfill material is compacted with a 15 kg hand tamper. **Mechanical compaction and sludging of the backfill material is not permitted!** During backfilling and compaction, keep checking for deformations or other signs of uneven compaction on the **earth shaft**.

- After backfilling/compaction of the lower part of the pit, the **inlet pipe and the empty pipe** are laid with a gradient (min. 1 %) to the tank and the **outlet pipe** is laid with a gradient (min. 1 %, the same or greater than for the inlet) away from the tank. The outlet pipe of the tank can be connected to an existing sewer or to a downstream infiltration system. If the outlet pipe is connected to an infiltration system, this must be at least 3 m away from the tank.
- The **earth shaft** is then **filled with water** up to the lower edge of the connections.
- For **backfilling/compaction up to approx. 200 mm below the top edge of the ground**, proceed as described for the lower part of the pit. Please note: Before backfilling/compaction around the connections, these must be checked for absence of stress and a solid fit!
- - The remaining backfilling can be done with topsoil or excavated soil (**non-cohesive, clayey, loamy**).

6.2 Installation as trafficable version with telescopic dome 95.0050.0072

In **preparation for the insertion** of the **earth shaft** into the excavation pit, the **bedding is made of backfill material** (200 mm thick) on the pit floor: Individual layers of 100 mm in height are introduced and heavily compacted (vibrator or 3 steps with hand tamper 15 kg per layer)). The surface must be exactly level.



It must be ensured on site that the tanks are not subjected to higher loads!



The containers may only be used in areas that can be driven over and are low-speed zones for cars!

- The tank and its installations must be checked to ensure that they are **intact**.
- The **insertion of the earth shaft** is to be carried out in such a way that it is introduced into the pit shock-free (e.g. with the aid of straps or ropes) and carefully placed onto the bottom bedding. It must be ensured that, if necessary, only the crane eyes provided for this purpose are used for fastening or lifting. Slinging on protruding tank parts (e.g. nozzles) or other attachments is not permitted!
- The **telescopic dome is put in place** and aligned. Only telescopic domes by the manufacturer with cover, loadable up to 15kN (see embossing in the cover) may be used.
- To **secure the earth shaft**, it must be filled with water up to a height of approx. 50 cm. The shaft or container is aligned exactly flat and level.
- The **backfilling/compaction in the lower part of the pit** takes place in 3 steps, whereby the earth shaft is filled to 1/3 with water and from the outside the backfill material is introduced at the same height. The backfill material is compacted with a 15 kg hand tamper (**no machine use!**). During backfilling and compaction, keep checking for deformations or other signs of uneven compaction on the **earth shaft**.
- After backfilling/compaction of the lower part of the pit, the **inlet pipe and the empty pipe** are laid with a gradient (min. 1 %) to the tank and the **outlet pipe** is laid with a gradient (min. 1 %, the same or greater than for the inlet) away from the tank. The outlet pipe of the tank can be connected to an existing sewer or

Installation instructions Earth Shafts

to a downstream infiltration system. If the outlet pipe is connected to an infiltration system, this must be at least 3 m away from the tank.

- The **telescopic dome** is pushed to the desired height and **provisionally fixed from the inside with the transport screws**.
- The **earth shaft** is then **filled with water** up to the lower edge of the connections.
- Further backfilling/compaction around and above the tank as well as up to the lower ring of the telescopic dome is carried out in the same way for the lower part of the pit. Ensure that connections are tension-free and secure!
- **Laterally around the telescopic dome**, a gravel base layer at least 300 mm in height (must be made of sand-lime bricks 2/45 or equivalent material) is introduced and compacted in layers of 100 mm with a 15 kg hand tamper (**no machine use!**) in three operations per layer. The area of the gravel base layer is to be provided so that it corresponds to the size of the excavation pit floor. The provisional fixation is to be removed gradually when the telescopic dome is fixed by the compacted backfill!
- In addition to the gravel base layer, an approx. 150 mm high underlay of dry mortar (ready-mix from the DIY store) is applied **underneath the frame of the telescopic dome**. This layer must be at least 200 mm wide and must be carried out directly on the telescopic dome.
- An approximately 100 mm high layer of backfill material is applied **above the gravel base layer**.
- The **remaining backfilling** can be carried out with paving, topsoil or excavated soil (non-cohesive, clay or clayey). It is recommended that lawn grids be installed in areas subject to traffic.
- **The container must be filled with water up to the beginning of the dome shaft when laying paving stones. The inlet, outlet and the supply pipe / empty pipe must be closed for this purpose until completion of the construction work.**



For the application of paving stones, only commercially available surface vibrators up to a maximum of 60kg may be used for compaction! Larger devices, or those known as hops, are not permitted!



When installing a trafficable version, always ensure that the shaft top is decoupled from the tank! Vehicle loads must not be transferred directly to the tank under any circumstances! The elements of the shaft extension must not be screwed together!

In ==> Figure 5, the different layers are illustrated using as an example Clearo-line Earth shafts depicted.

Installation instructions Earth Shafts

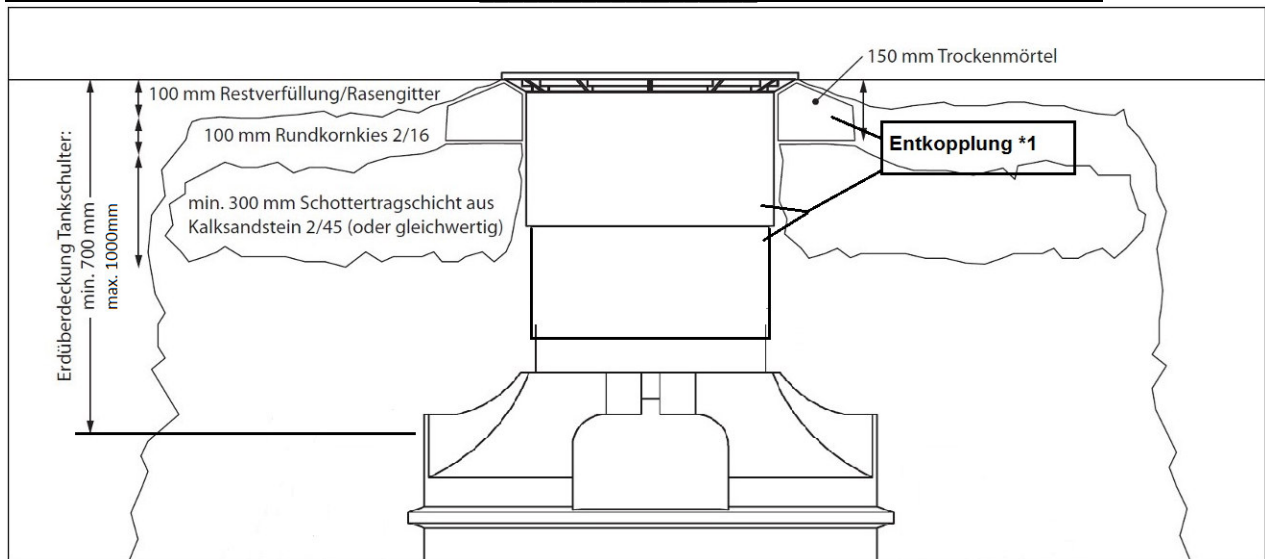

Figure 5: On-site construction of a passable superstructure with telescopic dome



The soil cover (based on the tank shoulder) must be at least 700 mm! The lateral bedding is carried out with rounded gravel grain 2/16. Layers of 100 mm are placed and compacted with a hand tamper (15 kg) in three operations per layer! Mechanical compaction is not permitted!

Decoupling *1 – the provisional fixation must be loosened and care must be taken to ensure that the lower part of the dome is separated from the upper part.

7 Maintenance and cleaning

Regular inspection and maintenance ensures increased functional reliability and service life of your rainwater shaft, wastewater shaft or soakaway. Cleaning of the containers and also the filter inserts should be carried out at regular intervals. The frequency of the maintenance intervals depends on the local conditions and is at the discretion of the operator.

The following applies to plastic covers: Clean the sand trap channel and screw bushings as and when required; lubricate screws and bushings. Check covers regularly for a secure / child-proof fit.