

SCHNITT A-A

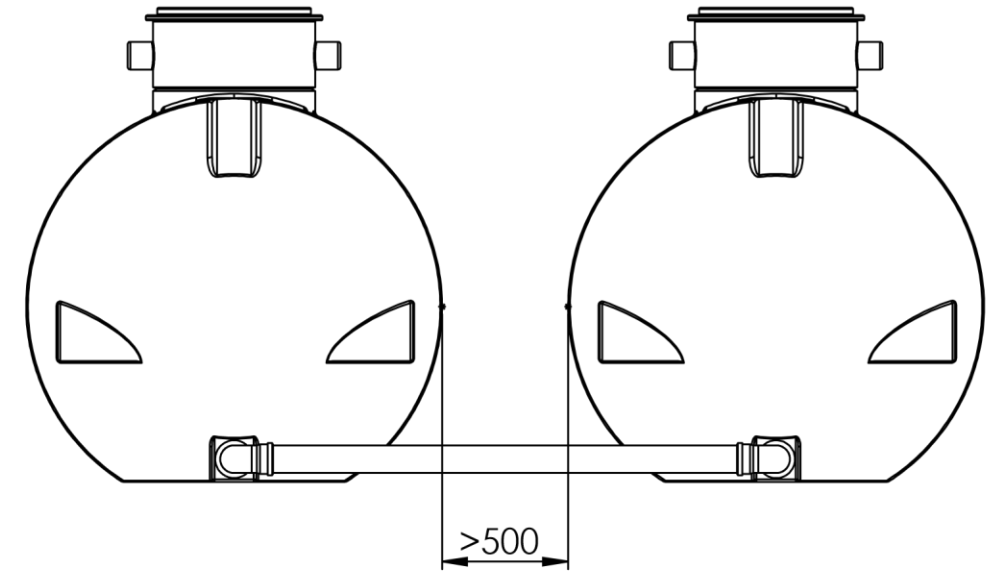

Änderungsbeschreibung/ revision text		Index	T.Graff 02.02.2017	-	Kundenzeichnung/ client's drawing	Index Kunde/ client's index
Werkstoff/material siehe Stückliste		Allg. Toleranzen/gen. tolerances				
-		DIN 16742 - TG9		Metallbauteile & Maschinell bearbeitete Flächen/ metal components & machined areas		
Masse/mass in kg		DIN 2768-1 f m c v				
	Masstab/scale 1:30	Benennung/title Ozeanis 8000 L 2 Behälter				
		Köver GmbH & CoKG		Kundenzeichnung/customer drawing		Kundennummer/client's No.
Schutzvermerk nach DIN ISO 16016 beachten! Refer to protection notice DIN ISO 16016!		Format/size A3	Blatt/sheet 1/1	Sach-Nr./basic number 35.8000.0010		
Keine Änderungen ohne Zustimmung der federführenden Konstruktion. / Any alterations are subject to the approval of the design department.						

H:\07-Technik\Produktdokumentation\Wassertechnik\Bilder gerendert\Bilder Gera Dez 2016 zur Thold-IT\Für Thold-IT-3D-Daten\3D-Daten\Komponenten\35.8000.0010 Ozeanis 8000 L duo